

Introduction



UNPACKING AND

ENGLISH

Congratulations on Your Purchase!

Your new high fidelity receiver is designed to deliver maximum enjoyment and years of trouble free service. Please take a few moments to read this manual thoroughly. It will explain the features and operation of your unit and help ensure a trouble free installation. Please unpack your unit carefully. We recommend that you save the carton and packing material. They will be helpful if you ever need to move your unit and may be required if you ever need to return it for service. Your unit is designed to be placed in a horizontal position and it is important to allow at least two inches of space behind your unit for adequate ventilation and cabling convenience.

To avoid damage, never place the unit near radiators, in front of heating vents, in direct sunlight, or in excessively humid or dusty locations. Connect your complementary components as illustrated in the following section.

	CAUTION RISK OF ELECTRIC SHOCK DO NOT OPEN	
CAUTION : TO REDUCE THE RISK OF ELECTRIC SHOCK, DO NOT REMOVE COVER (OR BACK). NO USER-SERVICEABLE PARTS INSIDE. REFER SERVICING TO QUALIFIED SERVICE PERSONNEL.		



This symbol is intended to alert the user to the presence of uninsulated "dangerous voltage" within the product's enclosure that may be of sufficient magnitude to constitute a risk of electric shock to persons.



This symbol is intended to alert the user to the presence of important operating and maintenance (servicing) instructions in the literature accompanying the appliance.

WARNING

To reduce the risk of fire or electric shock, do not expose this appliance to rain or moisture.

Caution : Do not block ventilation openings or stack other equipment on the top.

FOR U.S.A

■ **Note to CATV System Installer:** This reminder is provided to call the CATV system installer's attention to Article 820-40 of the NEC that provides guidelines for proper grounding and, in particular, specifies that the cable ground shall be connected to the grounding system of the building, as close to the point of cable entry as practical.

■ **FCC INFORMATION**

This equipment has been tested and found to comply with the limits for a Class B digital device, pursuant to Part 15 of the FCC Rules. These limits are designed to provide reasonable protection against harmful interference in a residential installation. This equipment generates, uses and can radiate radio frequency energy and, if not installed and used in accordance with the instructions, may cause harmful interference to radio communications. However, there is no guarantee that interference will not occur in a particular installation. If this equipment does cause harmful interference to radio or television reception, which can be determined by turning the equipment off and on, the user is encouraged to try to correct the interference by one or more of the following measures:

- Reorient or relocate the receiving antenna.
- Increase the separation between the equipment and receiver.
- Connect the equipment into an outlet on a circuit different from that to which the receiver is connected.
- Consult the dealer or an experienced radio/TV technician for help.

CAUTION: Any changes or modifications in construction of this device which are not expressly approved by the party responsible for compliance could void the user's authority to operate the equipment.

Caution regarding placement (Except for U.S.A and Canada)

To maintain proper ventilation, be sure to leave a space around the unit (from the largest outer dimensions including projections) equal to, or greater than, shown below.

Left and right panels: 5 cm
Rear panel: 5 cm
Top panel: 20 cm

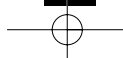

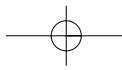

READ THIS BEFORE OPERATING

FOR U.S.A AND CANADA 120 V

FOR YOUR SAFETY

Units shipped to the U.S.A and Canada are designed for operation on 120 V AC only.

Safety precaution with use of a polarized AC plug. However, some products may be supplied with a nonpolarized plug.

CAUTION : To prevent electric shock, match wide blade of plug to wide slot, fully insert.

FOR EUROPE AND AUSTRALIA 230 V/240 V

FOR YOUR SAFETY

Units shipped to Australia are designed for operation on 240 V AC only.

To ensure safe operation, the three-pin plug supplied must be inserted only into a standard three-pin power point which is effectively earthed through the normal household wiring. Extension cords used with the equipment must be three-core and be correctly wired to provide connection to earth.

Improper extension cords are a major cause of fatalities. The fact that the equipment operates satisfactorily does not imply that the power point is earthed and that the installation is completely safe. For your safety, if in any doubt about the effective earthing of the power point, consult a qualified electrician.

PAN-EUROPEAN UNIFIED VOLTAGE

All units are suitable for use on supplies 230~240 V AC.

FOR OTHER COUNTRIES 115 V/230 V

FOR YOUR SAFETY

Units shipped to countries other than the above countries are equipped with an AC voltage selector switch on the rear panel. Refer to the following paragraph for the proper setting of this switch.

AC VOLTAGE SELECTION

This unit operates on 115/230 V AC. The AC voltage selector switch on the rear panel is set to the voltage that prevails in the area to which the unit is shipped. Before connecting the power cord to your AC outlet, make sure that the setting position of this switch matches your line voltage. If not, it must be set to your voltage in accordance with the following direction.

AC voltage selector switch

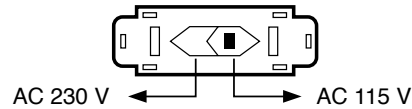

Move switch lever to match your line voltage with a small screwdriver or other pointed tool.

ENGLISH

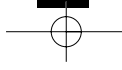

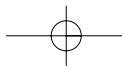

CONTENTS

ENGLISH

Introduction	
• UNPACKING AND INSTALLATION	2
• READ THIS BEFORE OPERATING YOUR UNIT	3
System Connections	5
Front Panel Controls	8
Universal Remote Controls	9
• OPERATING COMPONENTS WITH REMOTE CONTROL	11
• REMOTE CONTROL OPERATION RANGE	11
• LOADING BATTERIES	11
• USING FUNCTIONS OF REMOTE CONTROL	12
Operations	
• LISTENING TO A PROGRAM SOURCE	15
• SURROUND SOUND	18
• ENJOYING SURROUND SOUND	23
• LISTENING TO RADIO BROADCASTS	27
• RECORDING	29
• DIGITAL AUDIO RECORDING WITH MD RECORDER	30
• OTHER FUNCTIONS	31
Using the OSD	
• CURRENT STATUS DISPLAY	32
• MENU SCREEN	32
Troubleshooting Guide	35
Specifications	36
Setup Code Table	37

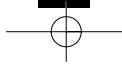

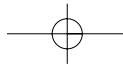

System Connections

- Do not plug the AC input cord into the wall AC outlet until all connections are completed.
- Be sure to observe the color coding when connecting audio and video cords.
- Make connections firmly and correctly. If not, it can cause loss of sound, noise or damage to the receiver.
- If the electricity fails or the AC input cord is left unplugged for more than 2 weeks, the memorized contents will be cleared. Should this happen, memorize them again.

ENGLISH

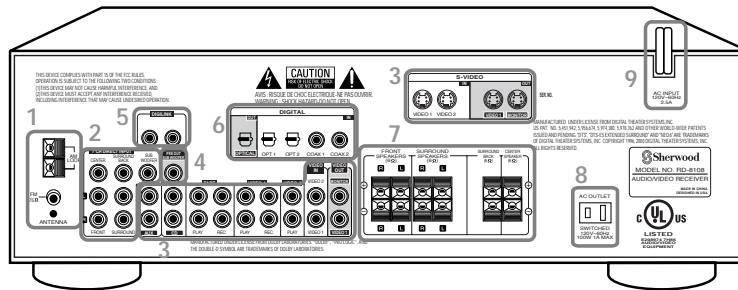

1. CONNECTING ANTENNAS

- Change the position of the FM indoor antenna until you get the best reception of your favorite FM stations.
- A 75Ω outdoor FM antenna may be used to further improve the reception. Disconnect the indoor antenna before replacing it with the outdoor one.
- Place the AM loop antenna as far as possible from the receiver, TV set, speaker cords and the AC input cord and set it to a direction for the best reception.
- If the reception is poor with the AM loop antenna, an AM outdoor antenna can be used in place of the AM loop antenna.

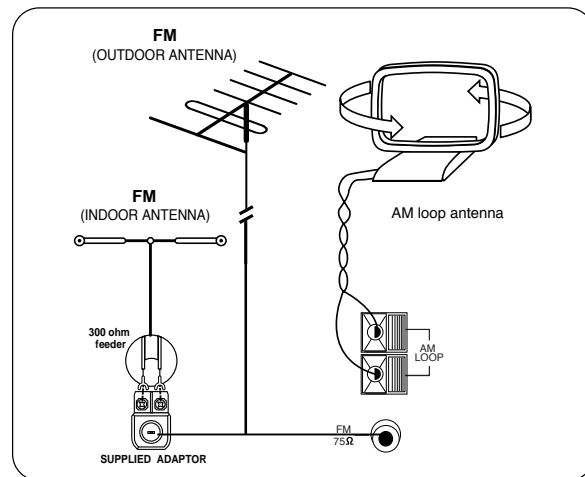

2. CONNECTING 7 CH DIRECT INPUTS

- Use these jacks to connect the corresponding analog outputs of a DVD player or external decoder, etc. that has 6 or 7 channel outputs.
- In case of 6 channel outputs, do not connect this SURROUND BACK input to your component. (For details, refer to the operating instructions of the component to be connected.)

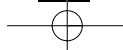
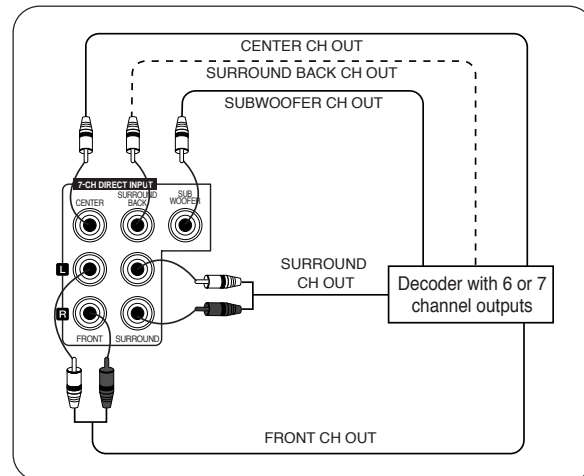

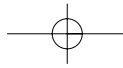

3. CONNECTING AUDIO/VIDEO COMPONENTS

- The AUX jacks may be connected to an additional audio component such as a CD player, a tape deck, etc.
- The TAPE PLAY/REC jacks may be connected to PLAY(OUT) / REC(IN) jacks of MD recorder.
- The VIDEO 2 jacks may also be connected to an additional video component such as a cable TV tuner, an LD player or satellite system.
- This unit incorporates S-VIDEO and composite (normal) VIDEO jacks.
- For your reference, the excellence in picture quality is as follows:
"S-VIDEO" > composite(normal) "VIDEO"
- A signal input into the composite(normal) VIDEO IN jack will be output in the composite(normal) VIDEO OUT jacks and a signal input into the S-VIDEO IN jack will be output in the S-VIDEO OUT jacks.

Note :

- When Sherwood DVD player such as V-756, etc. is connected to the DIGI LINK jack for system control, you should connect the DVD player to the "VIDEO 2" jacks of this unit. Because if the PLAY button, etc. is pressed on the DVD player, the "VIDEO 2" is automatically selected as an input source on this unit and the playback, etc. starts.

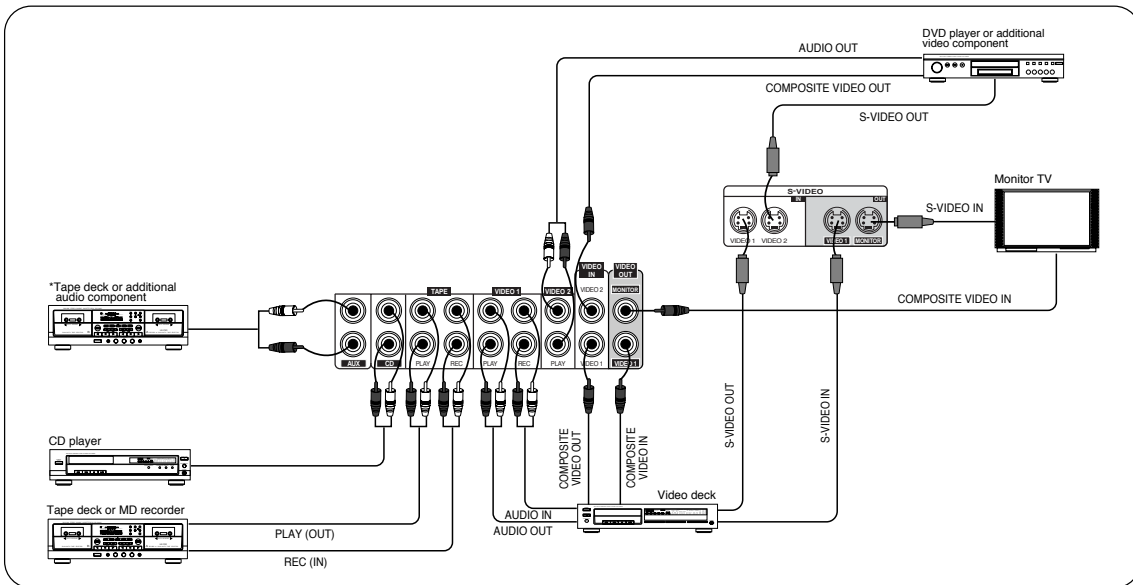

4. SUBWOOFER PRE OUT

connection

- To emphasize the deep bass sounds, connect a powered subwoofer.

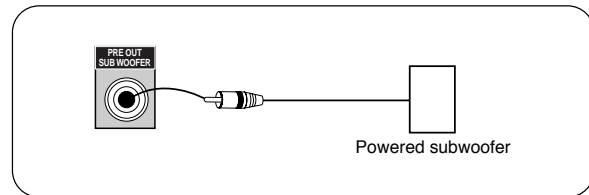

5. CONNECTING SYSTEM CONTROL

- Connect this jack to the DIGI LINK jack of the external Sherwood component that uses the DIGI LINK II or III remote control system.

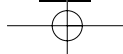
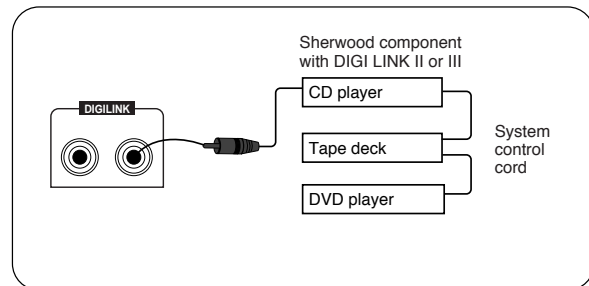

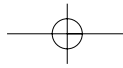

6. CONNECTING DIGITAL INs and OUT

- The COAXIAL or the OPTICAL DIGITAL OUTs of the components that are connected to CD and VIDEO 1~3 of this unit can be connected to these DIGITAL INs.
- If a digital recorder or other component with OPTICAL DIGITAL IN/OUT jacks is connected to the corresponding jacks of this unit, you can playback and/or record the high quality sound of CD's, etc. without analog conversion or degradation.
- A digital input should be connected to the components such as a CD player, LD player, DVD player, etc. capable of outputting DTS Digital Surround, Dolby Digital or PCM format digital signals, etc.
- For details, refer to the operating instructions of the component connected.
- When making the COAXIAL DIGITAL connection, be sure to use a 75Ω COAXIAL cord, not a conventional AUDIO cord.
- All of the commercially available optical fiber cords cannot be used for the equipment. If there is an optical fiber cord which cannot be connected to your equipment, consult your dealer or nearest service organization.

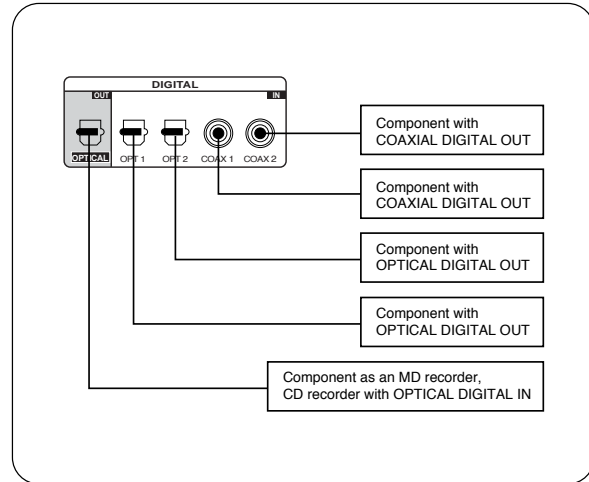

ENGLISH

7. CONNECTING SPEAKERS

- Be sure to connect speakers firmly and correctly according to the channel(left and right) and the polarity(+ and -). If the connections are faulty, no sound will be heard from the speakers, and if the polarity of the speaker connection is incorrect, the sound will be unnatural and lack bass.
- For installing the speakers, refer to "Speaker placement" on page 20.
- After installing the speakers, first adjust the speaker settings according to your environment and speaker layout. (For details, refer to "Adjusting the speaker settings" on page 21.)

Caution :

- Be sure to use the speakers with the impedance of 6 ohms or above.
- Do not let the bare speaker wires touch each other or any metal part of this unit. This could damage this unit and/or the speakers.

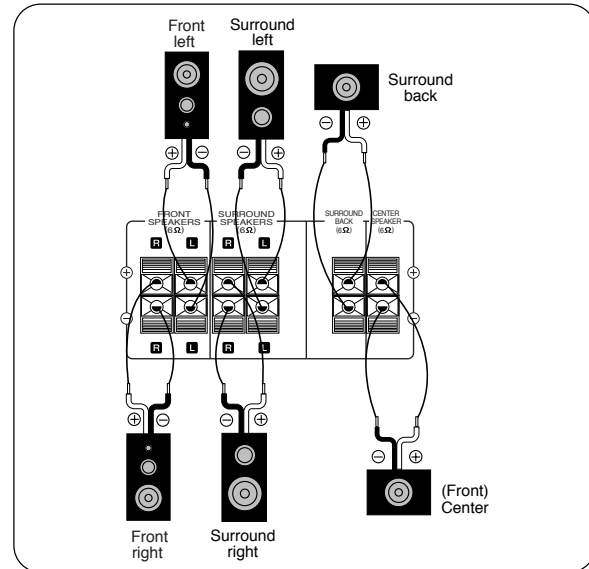

8. SWITCHED AC OUTLET

- This outlet is switched on(power-on mode) and off(standby mode) according to power control as follows(Maximum total capacity is 100 W):

Standby mode - switched AC outlet off
Power-on mode - switched AC outlet on

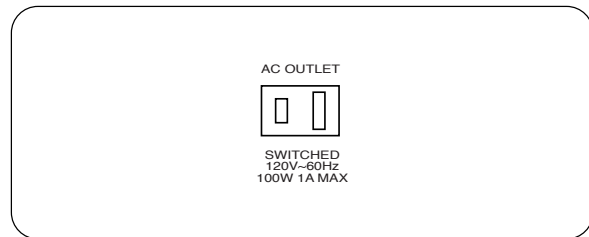

9. AC INPUT CORD

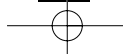
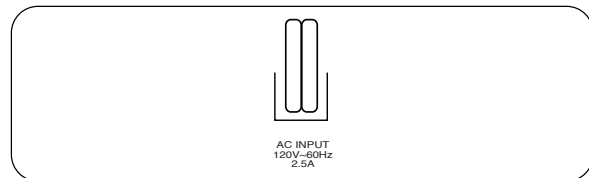

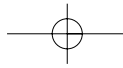

Front Panel Controls

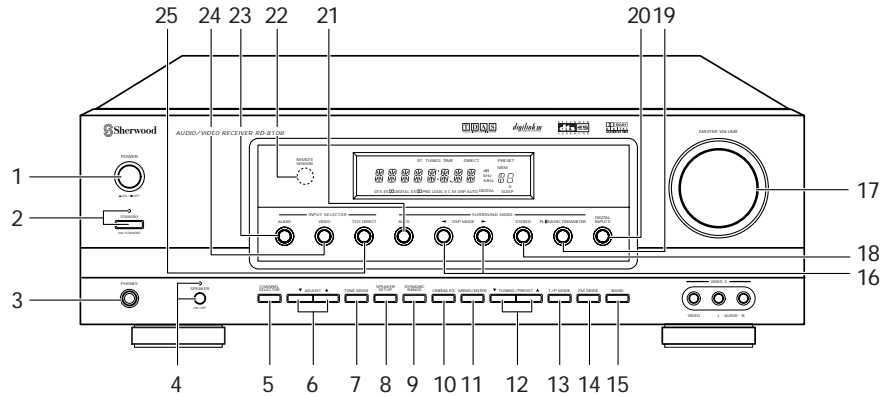

- | | |
|---|--------------------------------------|
| 1. POWER switch | 13. TUNING/PRESET MODE button |
| 2. STANDBY button/indicator | 14. FM MODE button |
| 3. HEADPHONE jack | 15. BAND button |
| 4. SPEAKER button/indicator | 16. DSP MODE UP / DOWN (▶/◀) buttons |
| 5. CHANNEL SELECTOR button | 17. MASTER VOLUME control knob |
| 6. ADJUST UP / DOWN (▲/▼) buttons | 18. STEREO button |
| 7. TONE MODE button | 19. PL II MUSIC PARAMETER button |
| 8. SPEAKER SETUP button | 20. DIGITAL INPUTS button |
| 9. DYNAMIC RANGE button | 21. AUTO button |
| 10. CINEMA EQ button | 22. Remote sensor |
| 11. MEMORY/ENTER button | 23. AUDIO input selector button |
| 12. TUNING/PRESET UP / DOWN (▲/▼) buttons | 24. VIDEO input selector button |
| | 25. 7 CH DIRECT button |

FLUORESCENT DISPLAY

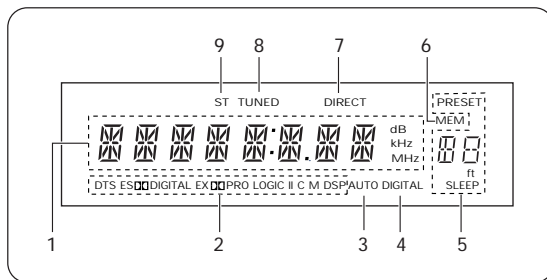

1. Input, frequency, volume level, operating information, etc.
2. Surround mode indicators
3. AUTO indicator
4. DIGITAL input signal indicator
5. PRESET number, SLEEP time, Speaker distance display
6. MEMORY indicator
7. DIRECT indicator
8. TUNED indicator
9. STEREO indicator

VIDEO 3 VIDEO/AUDIO INPUT JACKS

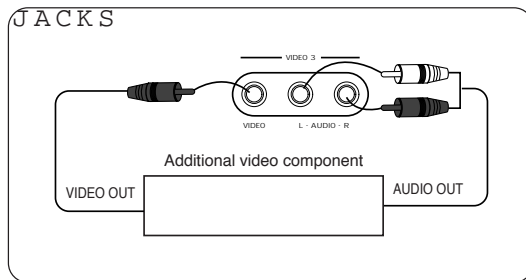

- The VIDEO 3 jacks may be also connected to an additional video component such as a camcorder, a LD

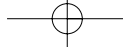

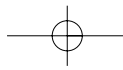

Universal Remote Controls

This universal remote control can operate not only this receiver but also most popular brands of audio and video components such as CD players, cassette decks, TVs, cable boxes, VCRs, DVD players, satellite receivers, etc.

- To operate 7 components other than this receiver, you should enter the setup code for each component.

(For details, refer to "USING FUNCTIONS OF REMOTE CONTROL" on page 12.)

■ Digi link system remote controls

This remote control can also operate Sherwood compatible components bearing the DIGI LINK (II or III) logo.

- For digi link system remote control operation, first make the DIGI LINK connections between Sherwood components.
- The numbered buttons on the remote control have different functions in different device modes. For details, refer to "FUNCTION TABLE of the NUMBERED BUTTONS" on the following page 10.

ENGLISH

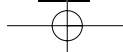
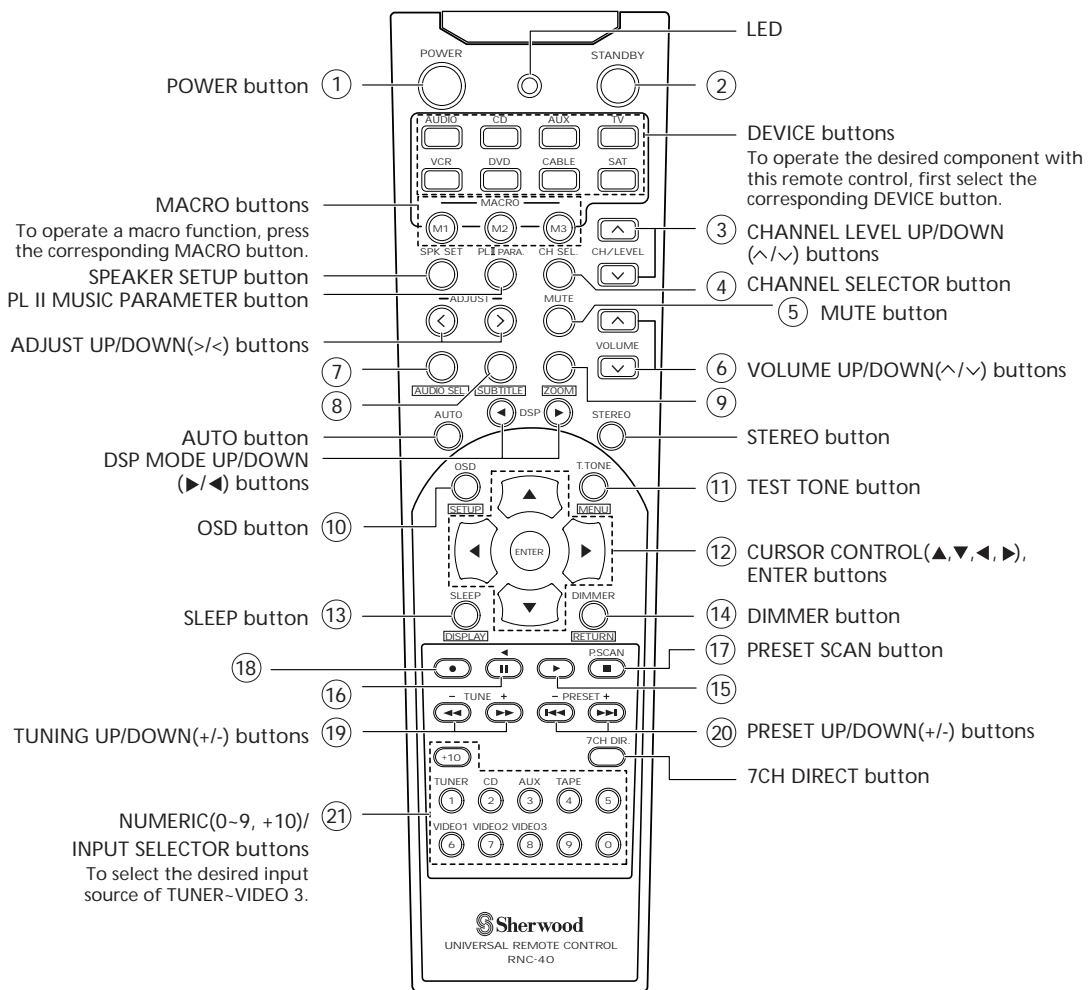

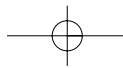

■ FUNCTION TABLE of the NUMBERED BUTTONS

Button symbol	Device to be controlled							
	CD (for CD player)	AUX (for tape deck)	TV (for TV)	VCR (for VCR)	DVD (for DVD player)	CABLE (for cable box)	SAT (for satellite receiver)	
①	POWER	POWER	POWER	POWER	POWER	POWER	POWER	
②	STANDBY (POWER OFF)	STANDBY (POWER OFF)	STANDBY (POWER OFF)	STANDBY (POWER OFF)	STANDBY (POWER OFF)	STANDBY (POWER OFF)	STANDBY (POWER OFF)	
③	—	—	CHANNEL LEVEL UP/DOWN(↖/↗)	CHANNEL LEVEL UP/DOWN(↖/↗)	—	CHANNEL LEVEL UP/DOWN(↖/↗)	CHANNEL LEVEL UP/DOWN(↖/↗)	
④	—	—	INPUT SELECTOR	INPUT SELECTOR	—	INPUT SELECTOR	INPUT SELECTOR	
⑤	—	—	MUTE	MUTE	—	MUTE	MUTE	
⑥	—	—	VOLUME UP/DOWN(↖/↗)	VOLUME UP/DOWN(↖/↗)	—	VOLUME UP/DOWN(↖/↗)	VOLUME UP/DOWN(↖/↗)	
⑦	—	—	—	—	AUDIO SELECTOR	—	—	
⑧	—	—	—	—	SUBTITLE	—	—	
⑨	—	—	—	—	ZOOM	—	—	
⑩	—	—	—	—	SETUP	—	—	
⑪	—	—	—	—	MENU	—	—	
⑫	—	—	—	—	CURSOR CONTROL	—	—	
	—	—	—	—	ENTER	—	—	
⑬	—	—	—	—	DISPLAY	—	—	
⑭	—	—	—	—	RETURN	—	—	
⑮	PLAY	FORWARD PLAY	—	PLAY	PLAY	—	—	
⑯	PAUSE	REVERSE PLAY	—	PAUSE	PAUSE	—	—	
⑰	STOP	STOP	—	STOP	STOP	—	—	
⑱	—	RECORD	—	RECORD	—	—	—	
⑲	—	REWIND(↶)/ FAST FORWARD(↷)	—	REWIND(↶)/ FAST FORWARD(↷)	REVERSE SEARCH(↶)/ FORWARD SEARCH(↷)	—	—	
⑳	REVERSE SKIP(↶)/ FORWARD SKIP(↷)	—	—	—	REVERSE SKIP(↶)/ FORWARD SKIP(↷)	—	—	
㉑	NUMERIC	—	NUMERIC	NUMERIC	NUMERIC	NUMERIC	NUMERIC	

Notes:

- Some functions for each component may not be available or may work differently.
- Depending on other kinds of components that are available for each DEVICE button, some functions may not be available or may work differently, too.
- For details about functions, refer to the operating instructions of each component.

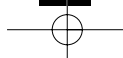

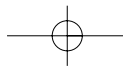

- 1 Enter the setup code for each component other than this receiver you wish to control. For details, refer to "Entering a setup code" on page 12.
- 2 Turn on the component you want to operate.
- 3 Press the DEVICE button on the remote control corresponding to the component you wish to operate.
- 4 Aim the remote control at the REMOTE SENSOR of the component you wish to control and press the button corresponding to the operation you want.
 - When operating a Sherwood CD player or tape deck using digi link system remote control, aim the remote control at the REMOTE SENSOR of this receiver. However, to operate a Sherwood DVD player, aim at the REMOTE SENSOR of the corresponding component.

- Use the remote control unit within a range of about 7 meters (23 feet) and angles of up to 30 degrees aiming at the remote sensor.

ENGLISH

LOADING BATTERIES

- When the remote control does not operate, the old batteries should be replaced. In this case, load new batteries within several minutes after removing old batteries.
- If the batteries are removed or have been exhausted for a longer period of time, memorized contents will be cleared. Should this happen, you should memorize them again.

- 1 Remove the cover.
- 2 Load two batteries matching the polarity.

2 x 1.5V
("AAA" size)

 - Remove the batteries when they are not used for a long time.
 - Do not use the rechargeable batteries(Ni-Cd type).
 - Be sure to use alkaline batteries.

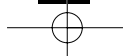

USING FUNCTIONS OF REMOTE

- This remote control can control up to 8 different components.
- Before operating audio and video components other than this receiver with using this remote control, the setup code for each component should be entered.
- For system remote control operation, "000" was stored previously in the memory of the device button "CD" for Sherwood CD player, "DVD" for Sherwood DVD player and "AUX" for Sherwood tape deck respectively as its factory setup code. So, you don't need to enter its code for each Sherwood component except in such a case that its code does not work.

Entering a setup code

1 Turn on the component you want to control

2 Find the setup codes according to the type and the brand name of your component, referring to "Setup Code Table" on page 37.

3 Press and hold down both the ENTER button and the DEVICE button you want for more than 1 second.

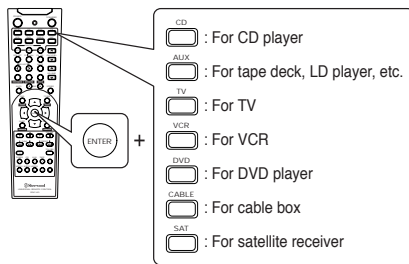

- The LED will flicker once.

Note:

- The AUDIO button is unavailable for the audio components other than this receiver.

4 Enter a 3 digit code, aiming the remote control at the remote sensor on the component. Example) When entering "001".

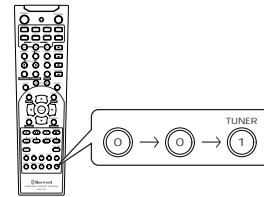

- If entering is performed successfully, the LED will flicker twice.
- To be sure that the setup code is correct, press the POWER(or STANDBY) button. If your component is tuned off, the setup code is correct.
- When your component is not turned off, repeat the above steps 2 to 4, trying each code for your component until you find one that works.

Notes:

- If the LED did not flicker twice, then repeat the above steps 3 to 4 and try entering the same code again.
- Manufacturers may use different setup codes for the same product category. For that reason, it is important that you check to see if the code you have entered operates as many controls as possible. If only a few functions operate, check to see if another code will work with more buttons.
- When operating a Sherwood CD player or tape deck using the system remote control, aim the remote control at the REMOTE SENSOR on this receiver. However, in case of Sherwood DVD player and MD recorder, aim it at the REMOTE SENSOR on the corresponding component.

5 Repeat the above steps 1 to 4 for each of your components.

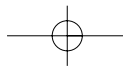

Using a punch-through function

This remote control may be programmed to operate either the AUDIO volume punch-through or the TV volume and/or TV channel punch-through in conjunction with any of the eight components controlled by this remote control.

For example, since this receiver will likely be used as the sound system while watching TV, you may want to adjust this receiver's volume although this remote control is set to control the TV.

- When programming this remote control for the AUDIO volume punch-through, press and hold down both "AUDIO" button and "VOLUME \wedge " button for more than 1 second.

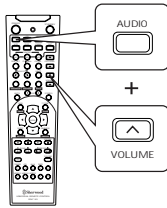

- If programming is performed successfully, the LED will flicker twice.
- When you want either TV volume or TV channel punch-through, press and hold down both "TV" button and either "VOLUME \wedge " or "CH \wedge " button for more than 1 second.

Note :

- If you use one of AUDIO and TV volume punch-through functions, you cannot use the other.

■ Removing a punch-through function

- When removing the AUDIO volume punch-through, press and hold down both "AUDIO" button and "VOLUME ∇ " button for more than 1 second.

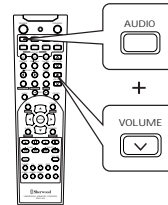

- If removing is performed successfully, the LED will flicker twice.
- When you want to remove either TV volume or TV channel punch-through, press and hold down both "TV" button and either "VOLUME ∇ " or "CH ∇ " button for more than 1 second.

■ Removing all punch-through functions

Press and hold down both "AUDIO" button and "AUTO" button for more than 1 second.

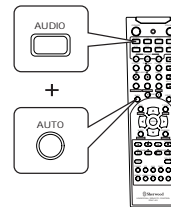

- If removing all punch-through functions is performed successfully, the LED will flicker twice.

ENGLISH

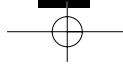

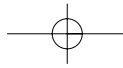

Programming a macro function

- The macro function enables you to program a series of button operations (up to 10) on this remote control into a single button.
- You can store up to three separate macro command sequences into “M1”, “M2” and “M3” buttons.

1 Press and hold down both “ENTER” button and one of three NUMERIC buttons (“1”~“3”) corresponding to “M1”~“M3” buttons for more than 1 second.

Example) When programming a series of button operations into “M1” button.

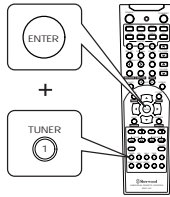

- If the macro mode is entered, the LED will flicker once.

2 Press the operation buttons you want to program in order.

■ Note:

You should press the corresponding DEVICE buttons before pressing each operation button.

Example) When playing a DVD on the DVD player connected to VIDEO 2 jacks of this receiver.

1. Press “AUDIO” button to control this receiver.
2. Press “POWER” button to turn this receiver on.
3. Press “AUDIO” button to control this receiver.
4. Press “VIDEO 2(7)” button to select the desired input source.
5. Press “DVD” button to control the DVD player.
6. Press “POWER” button to turn the DVD player on.
7. Press “DVD” button to control the DVD player.
8. Press “▶” button to start playback.



3 Press “ENTER” button.

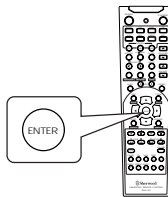

- If the programming is performed successfully, the LED will flicker twice.

■ To remove a macro program

- When removing a macro program, perform the above steps 1 and 3, but ignore the step 2.

■ To change a macro program

- When a new macro program is stored into a MACRO button with performing the above steps 1 to 3, the previous macro program is cleared from the memory of the MACRO button.

Operating a macro function

- Aim the remote control at the REMOTE SENSORS of the components to be controlled and press the MACRO button you want.
- Example) When pressing “M1” button.

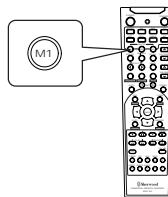

■ Notes:

- The codes programmed into a MACRO button will be transmitted at an interval of 0.5 seconds. However, some components may not be able to complete one operation in 0.5 seconds and may miss the next code. In this case, the macro function cannot control the corresponding components correctly.
- Be sure to use the remote control within the remote control operation range of the components.
- Depending on the operation status of the components, etc., the macro function cannot control the corresponding components correctly.

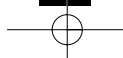

Operations

- Note : Before operating this receiver with the supplied remote control, refer to “Universal Remote Controls” on page 9 for details about operation.

LISTENING TO A PROGRAM

Before operation

- Enter the standby mode.

- The STANDBY indicator lights up. This means that the receiver is not disconnected from the AC mains and a small amount of current is retained to support the memorized contents and operation readiness.
- To switch the power off, push the POWER switch again.
- Then the power is cut off and the STANDBY indicator goes off.



- 1 In the standby mode, turn the power on.

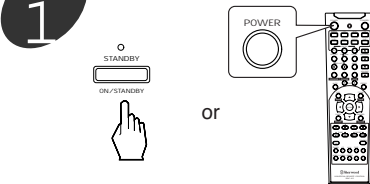

- Each time the STANDBY button on the front panel or the POWER button on the remote control is pressed, the receiver is turned on to enter the operating mode or off to enter the standby mode.
- In the standby mode, if the INPUT SELECTOR button is pressed, the receiver is turned on automatically and the desired input is selected.

- 2 Switch the speakers on.



- Then the SPEAKER indicator lights up and the sound can be heard from the speakers connected to the speaker terminals.
- When using the headphone for private listening, press the SPEAKER button again to switch the speakers off.

- 3 Select the desired input source.

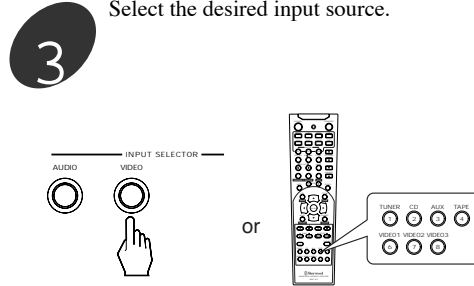

- Each time the “AUDIO” button on the front panel is pressed, the input source changes as follows;
 → TUNER → CD → TAPE → AUX
 (frequency display)

- Each time the “VIDEO” button on the front panel is pressed, the input source changes as follows;
 → VIDEO 1 → VIDEO 2 → VIDEO 3

- When selecting the 7 CH DIRECT as desired,

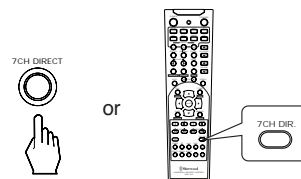

- “7-DIRECT” is displayed and the 7 or 6 separate analog signals from the component connected to this input can be controlled only by tone(bass, treble) and volume depending on the surround back speaker setting.
- Press the 7 CH DIRECT button or select the desired input source to cancel the 7 CH direct function.
- These analog signals can be heard only, not recorded.

When CD, VIDEO 1~3 is selected as an input source

4 Select the digital or analog input connected as desired.



- Each time this button is pressed, the corresponding input is selected as follows :

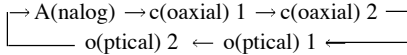

- To listen to a DTS or Dolby Digital program source in the 2-CH downmix mode, in the stereo mode, the corresponding digital input should be selected. (For details, refer to “Downmixing into 2 front channels” on page 26.)

■Notes :

- When the selected optical or coaxial digital input is not connected, the “DIGITAL” indicator flickers, meaning no sound. (Refer to “ENJOYING SURROUND SOUND” on page 23.)
- The sound from the component connected to the selected digital input can be heard regardless of the selected input source.

5 Operate the selected component for playback.

- When playing back the program sources with surround sound, refer to “ENJOYING SURROUND SOUND” on page 23.

6 Adjust the (overall) volume.

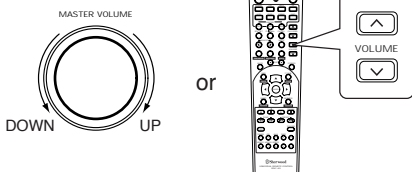

7 To compensate for edgy or shrill movie sound tracks.



- Then “C-EQ OFF” is scrolled.
- Press it again to work, the “C-EQ ON” is scrolled.
- When 96 kHz PCM(2 CH stereo) signals are input, the cinema EQ function does not work.

8 To mute the sound.

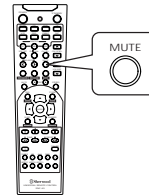

- “MUTE” will flicker.
- To resume the previous sound level, press it again.

9 To listen with the headphones.



- Ensure that the SPEAKER button is set to off.
- When listening to a DTS or Dolby Digital program source, if the headphones are plugged and the SPEAKER button is set to off, it enters the 2-CH downmix mode automatically. (For details, refer to “Downmixing into 2 front channels” on page 26.)

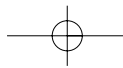

Adjusting the tone(bass and treble)

Enter the tone mode.



- Each time this button is pressed, the corresponding tone mode is selected and shown for several seconds as follows:

→ BASS → TRBL(treble) → TONE ON

- When the tone mode is off, "TONE OFF" is shown.

At the desired tone mode, adjust the tone as desired.

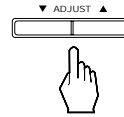

- At "TONE ON" mode, you can select "TONE OFF" mode and vice versa.

TONE ON: When adjusting the tone for your taste.

⇕ ("DIRECT" indicator goes off.)

TONE OFF: When listening to a program source without the tone effect.

("DIRECT" indicator lights up.)

- In general, we recommend the bass and the treble to be set to 0(flat) level.

■ Notes:

- If the tone display disappears, start from the step 10 again.
- Extreme settings at high volume may damage your speakers.
- When the digital signals from DTS or Dolby Digital program sources are input in available surround mode or the 7 CH DIRECT is selected as an input source, you cannot adjust the tone and can hear a program source without the tone effect.

ENGLISH

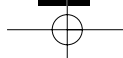

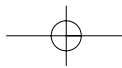

SURROUND SOUND

- This receiver incorporates a sophisticated Digital Signal Processor that allows you to create optimum sound quality and sound atmosphere in your personal Home Theater.

Surround modes

■ DTS Digital Surround

DTS Digital Surround(also called simply DTS) is a multi-channel digital signal format which can handle higher data rates than Dolby Digital. Although both Dolby Digital and DTS are 5.1 channel formats, discs bearing the “” are generally thought to provide better sound quality due to the lower audio compression required. It also provides wide dynamic range and separation, resulting in magnificent sound.

■ DTS - ES Extended Surround™

This is a new multi channel digital signal format which greatly improves the 360- degree surround impression and space expression thanks to further expanded surround signals, offering high compatibility with the conventional DTS format.

In addition to the 5.1 channels, DTS-ES Extended Surround also offers the surround back (sometimes also referred to as “surround center”) channel for surround playback with a total of 6.1 channels. DTS-ES Extended Surround includes two signal formats with different surround signal recording methods as follows:

• DTS-ES™ Discrete 6.1

Because the signals for 6.1 channels (including the surround back channel) are fully independent, it is possible to achieve a sense that the acoustic image are moving about freely among the background sounds surrounding the listener from 360 degrees.

Though maximum performance is achieved when sound tracks recorded with this system are played using a DTS -ES decoder, when played with a conventional DTS decoder, the surround back channel signals are automatically downmixed to the surround left and surround right channels so that none of the signal components are lost.

• DTS - ES™ Matrix 6.1

With this format, the additional surround back channel signals undergo matrix encoding and are input to the surround left and surround right channels beforehand. During playback, they are decoded to the surround left, surround right and surround back channels.

Because the bit stream format is 100% compatible with conventional DTS signals, the effect of the DTS-ES Matrix 6.1 format can be achieved even with DTS 5.1- channel signal sources. Of course, it is possible to play DTS-ES Matrix 6.1 - channel signal sources with a DTS 5.1 - channel decoder.

When DTS-ES Discrete 6.1 or Matrix 6.1 sources are decoded with a DTS - ES decoder, the format is automatically detected upon decoding and the optimum surround mode is selected. However, some DTS - ES Matrix 6.1 sources may be detected as DTS sources. In this case, the DTS - ES Matrix mode should be selected manually to play these sources.

■ DTS Neo : 6™ surround

This mode applies conventional 2-channel signals such as digital PCM or analog stereo signals to the high precision digital matrix decoder used for DTS-ES Matrix 6.1 to achieve 6.1-channel surround playback. DTS Neo : 6 surround includes two modes for selecting the optimum decoding for the signal source.

• DTS Neo : 6 Cinema

This mode is optimum for playing movies. Decoding is performed with emphasis on separation performance to achieve the same atmosphere with 2-channel sources as with 6.1-channel sources.

• DTS Neo : 6 Music

This mode is suited mainly for playing music. The front left and front right signals bypass the decoder and are played directly so there is no loss of sound quality, and the effect of the surround signals from the center, surround left, surround right and surround back channels adds a natural sense of expansion to the sound field.

“DTS”, “DTS-ES Extended Surround” and “Neo : 6” are trademarks of Digital Theater Systems, Inc.

■ Dolby Digital

Dolby Digital is the multi- channel digital signal format developed by Dolby Laboratories. Discs bearing the “” includes the recording of up to 5.1 channels of digital signals, which can reproduce much better sound quality, spatial expansion and dynamic range characteristics than the previous Dolby Surround effect.

■ Dolby Digital EX

This mode creates the back (sometimes also referred to as “surround center”) signals from the surround left and right signals in Dolby Digital 5.1 channel source using a matrix decoder and provides 6.1 channel surround playback. For the best results, this mode should be selected during playback of sources(bearing the “”) recorded in Dolby Digital Surround EX. With this additional channel, you can experience more dynamic and realistic moving sound especially.

When Dolby Digital EX sources are decoded with a Dolby Digital EX decoder, the format is automatically detected upon decoding and the Dolby Digital EX mode is selected. However, some Dolby Digital EX sources may be detected as Dolby Digital sources. In this case, the Dolby Digital EX mode should be selected manually to play these sources.

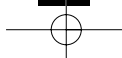

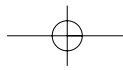

■ Dolby Pro Logic

Dolby Pro Logic is a specially encoded two channel surround format which consists of four channels (front left, center, front right and surround). Sources bearing the “  ” provide the theater-like surround sound.

The surround channel is monaural, but is played through both surround speakers.

■ Dolby Pro Logic II surround

This mode applies conventional 2- channel signals such as digital PCM or analog stereo signals as well as Dolby Surround signals, etc. to surround processing to offer improvements over conventional Dolby Pro Logic circuits. Dolby Pro Logic II surround includes two modes as follows:

• *Dolby Pro Logic II Cinema*

When enjoying movies, this mode allows you to further enhance the cinematic quality by adding processing that emphasizes the sounds of the action special effects.

• *Dolby Pro Logic II Music*

When listening to music, this mode allows you to further enhance the sound quality by adding processing that emphasizes the musical effects.

■ Dolby Virtual

This mode employs sophisticated digital processing to create the illusion of “phantom” speakers, this mode allows you to experience surround sound effects from Dolby Digital, Dolby Surround or 2-channel (recorded in digital PCM or analog stereo) sources, through just a single pair of front speakers.

Manufactured under license from Dolby Laboratories. “Dolby”, “Pro Logic”, and the double-D symbol are trademarks of Dolby Laboratories.

- When using the 7 CH DIRECT INPUTs to playback the sound from an additional multichannel decoder for surround sound, you can enjoy the corresponding surround sound, too. For details, refer to the operating instructions of the component to be connected.

The following modes apply conventional 2-channel signals such as digital PCM or analog stereo signals to high performance Digital Signal Processor to recreate sound fields artificially. Select one of the three provided surround modes according to the program source you want to play.

■ Theater

This mode provides the effect of being in a movie theater when watching a movie.

■ Hall

This mode provides the ambience of a concert hall for classical music sources such as orchestral, chamber music or an instrumental solo.

■ Matrix

This mode reproduces a delayed signals from the surround channels to emphasize the sense of expansion for music sources.

For your reference, the sound from each channel can be reproduced according to the surround modes as follows:

Modes \ Channels	FRONT L/R	(FRONT) CENTER	SURROUND L/R	SURROUND BACK (CENTER)	SUBWOOFER
DTS	○	○	○	—	○
DTS ES DISCRETE/MATRIX	○	○	○	○	○
DTS NEO:6 MOVIE/MUSIC	○	○	○	○	—(*)
DOLBY DIGITAL	○	○	○	—	○
DOLBY DIGITAL EX	○	○	○	○	○
DOLBY PRO LOGIC	○	○	○	—	—(*)
DOLBY PRO LOGIC II CINEMA/MUSIC	○	○	○	—	—(*)
DOLBY VIRTUAL	○	—	—	—	○/—
MATRIX	○	○	○	○	—(*)
Other Surround	○	○	○	—	—(*)
STEREO	○	—	—	—	—(*)
7 CH DIRECT	○	○	○	○	○

- Depending on the speaker settings and the number of the encoded channels, the sound from the corresponding channels cannot be reproduced. (For details, refer to “Adjusting the speaker settings” on page 21.)

(*): Depending on the speaker settings, the sound from the subwoofer channel may be reproduced.

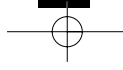

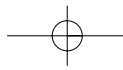

Speaker placement

Ideal speaker placement varies depending on the size of your room and the wall coverings, etc. The typical example of speaker placement and recommendations are as follows :

■ Front left and right speakers and center speaker

- Place the front speakers with their front surfaces as flush with TV or monitor screen as possible.
- Place the center speaker between the front left and right speakers and no further from the listening position than the front speakers.
- Place each speaker so that sound is aimed at the location of the listener's ears when at the main listening position.

■ Surround left and right speakers

- Place the surround speakers approximately 1 meter (40 inches) above the ear level of a seated listener on the direct left and right of them or slightly behind.

■ Surround back speaker

- Place the surround back speaker at the rear center facing the front at a slightly higher position (0 to 10 inches) than the surround speakers.
- We recommend installing the surround back speaker at a slightly downward facing angle. This effectively prevents the surround back channel signals from reflecting off the TV or screen at the front center, resulting in interference and making the sense of movement from the front to the back less sharp.

■ Subwoofer

- The subwoofer reproduces powerful deep bass sounds.
Place a powered subwoofer anywhere in the front as desired.

■ Notes :

- When using a conventional TV, to avoid interference with the TV picture, use only magnetically shielded front left and right and center speakers.
- To obtain the best surround effects, the speakers except the subwoofer should be full range speakers.

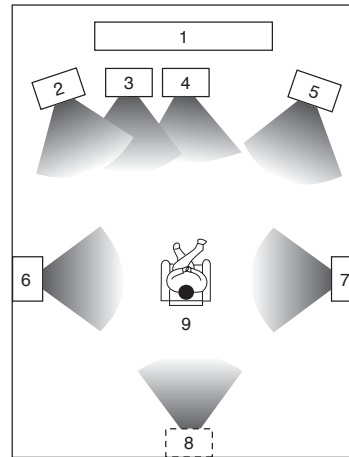

- | | |
|------------------------|---------------------------|
| 1. TV or screen | 6. Surround left speaker |
| 2. Front left speaker | 7. Surround right speaker |
| 3. Subwoofer | 8. Surround back speaker |
| 4. Center speaker | 9. Listening position |
| 5. Front right speaker | |

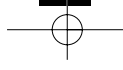
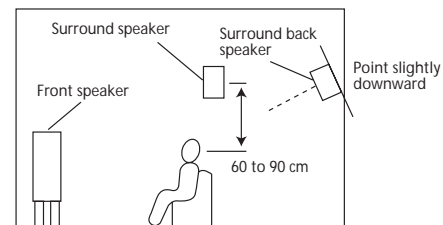

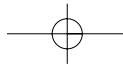

Adjusting the speaker settings

- After you have installed this unit and connected all the components, you should adjust the speaker settings for the optimum sound acoustics according to your environment and speaker layout.
- There are two kinds of speaker settings for speaker size and speaker distance.

■ Speaker size settings

Select the corresponding settings depending on the sizes of the connected speakers and whether the speakers are connected or not.

- Depending on your speaker type, you can select one of these following settings.

Large : Select this when connecting speakers that can fully reproduce sounds below 80 Hz.

Small : Select this when connecting speakers that cannot fully reproduce sounds below 80 Hz.

When this is selected, sounds below 80 Hz are sent to the subwoofer or the front speakers depending on whether the subwoofer setting is Yes or No.

None : Select this when no speakers are connected.

When this is selected, sounds are sent to the front speakers.

Yes / No : Select the desired depending on whether a subwoofer is connected or not.

- Depending on relationship between speakers, settings possible for each speaker are as follows:

Front L/R	Center	Surr. L/R	Surr. Back	Subwoofer
Large	Large	Large	Large	Yes or No
			Small	
		Small	Small	
			None	
		None	Large	
			None	
	Small	Large	Large	
			Small	
		Small	Small	
			None	
		None	Large	
			None	
None	Large	Large		
		Small		
	Small	Small		
		None		
	None	Large		
		None		
Small	Small	Small	Yes	
		None		
	None	Small		
		None		
	None	Small		
		None		

■ Speaker distance settings

When enjoying 5.1 channel surround playback with Dolby Digital and DTS sources, it is ideal that the center and surround speakers should be the same distance from the main listening position as the front speakers. By entering the distance differences between front and center speakers(Cd) and front and surround speakers(Sd), the delay times of center and surround speakers are automatically adjusted to create an ideal listening environment virtually as if the center and surround speakers were at their ideal locations respectively as below:

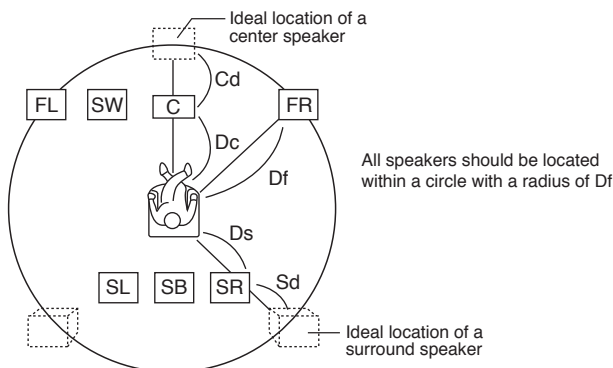

$$Cd = Df - Dc$$

$$Sd = Df - Ds$$

Cd : Center distance difference
 Sd : Surround distance difference
 Df : Front speaker distance
 Dc : Center speaker distance
 Ds : Surround speaker distance

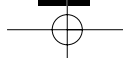

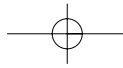

Refer to the previous page and adjust the speaker settings

Note : When the SPEAKER button is set to off or the 7 CH DIRECT is selected as an input source, the speaker setting function cannot be available.

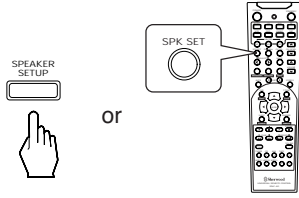
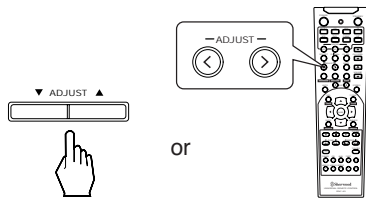
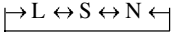
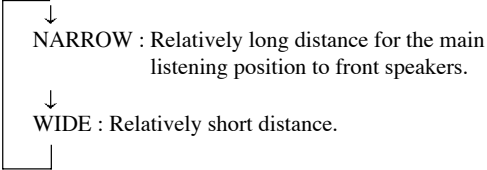
When selecting each setting mode	When adjusting the selected setting mode to the desired setting
 <ul style="list-style-type: none"> Each time the SPEAKER SETUP button is pressed, the speaker setting mode changes in succession and is displayed for several seconds as follows. When the speaker setting mode disappears, press the SPEAKER SETUP button repeatedly to select the desired mode. 	 <ul style="list-style-type: none"> Each time the ADJUST UP(▲ / >) or DOWN(▼ / <) button is pressed, one of the settings is selected and displayed for several seconds as follows.
<ul style="list-style-type: none"> When selecting the front-center-surround speaker setting mode. “FL - CL - SL” 	<ul style="list-style-type: none"> You can select one of 11 different speaker settings. FL - CL - SL / FL - CL - SN / FL - CS - SL / FL - CN - SL / FL - CS - SN / FL - CN - SS / FS - CS - SS / FS - CS - SN / FS - CN - SS / FL - CS - SS / FL - CL - SS (F: Front, C: Center, S: Surround, L: Large, S: Small, N: None)
<ul style="list-style-type: none"> When selecting the surround back speaker setting mode. “SUR B - L” 	 <ul style="list-style-type: none"> Depending on the surround speaker setting, you cannot select “L” or/and “S”.
<ul style="list-style-type: none"> When selecting the subwoofer setting mode. “SUB W - Y” 	<p>Y(es) ↔ N(o)</p> <ul style="list-style-type: none"> When the front speaker is set to “S”, the subwoofer is automatically set to “Y”.
<ul style="list-style-type: none"> When selecting the center distance difference mode. “CENTER 00 (ft)” 	<ul style="list-style-type: none"> You can adjust the distance difference within the range of 0 ~ 5 feet in 1 feet intervals. 00 (ft) ~ 05 (ft)
<ul style="list-style-type: none"> When selecting the surround distance difference mode. “SURROUND 05 (ft)” 	<ul style="list-style-type: none"> You can adjust the distance difference within the range of 0 ~ 15 feet in 1 feet intervals. 00 (ft) ~ 15 (ft)
<ul style="list-style-type: none"> When selecting the Dolby Virtual delay time mode. “NARROW” This mode can work only in the Dolby Virtual mode. In the other surround modes, this setting is just displayed. 	 <p>NARROW : Relatively long distance for the main listening position to front speakers.</p> <p>WIDE : Relatively short distance.</p>

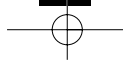

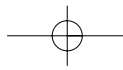

ENJOYING SURROUND SOUND

1

Depending on the input digital signal format, select the desired decoding mode.

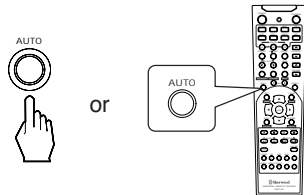

- Each time the AUTO button is pressed, the decoding mode changes as follows :

IN-AUTO : The input digital signal format(DTS, Dolby Digital or PCM(2 channel stereo), etc.) used by the selected digital input source is detected automatically to perform the necessary decoding process for optimum surround mode.
 IN-DTS : The DTS signal processing is performed only when DTS signals are input.
 IN-PCM : The PCM signal processing is performed only when PCM signals are input.

■ Notes :

- Only when the digital input is selected as signal input for the input sources except TUNER, TAPE and AUX, the decoding mode can be selected.
- Noise may be generated at the beginning of playback and while searching during DTS playback in the IN-AUTO mode. In this case, try playing in the IN-DTS mode.

2

Select the desired surround mode.

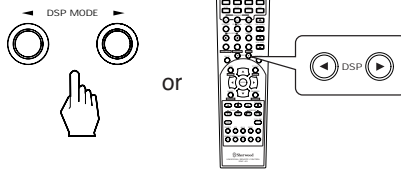

- Each time the DSP MODE ◀ or ▶ is pressed, the surround mode changes depending on the input signal format and the selected decoding mode as follows :

※When Dolby Digital signals are input in the IN-AUTO mode, one of the following modes can be selected depending on the number of the recorded channels.

- *Dolby Digital 5.1 or Dolby Digital EX 6.1 channel sources :*
(DOLBY DIGITAL EX,) DOLBY DIGITAL and DOLBY VIRTUAL
- *Dolby Digital 2-channel sources :*
(DOLBY DIGITAL EX,) DOLBY PRO LOGIC II CINEMA, DOLBY PRO LOGIC II MUSIC, DOLBY PRO LOGIC and DOLBY VIRTUAL
() : possible only when surround back speaker setting is not "N".

※When PCM(2 channel stereo) signals are input in the IN-AUTO or IN-PCM mode, one of the following modes can be selected.

- DOLBY PRO LOGIC II CINEMA, DOLBY PRO LOGIC II MUSIC, DOLBY PRO LOGIC, DOLBY VIRTUAL, DTS NEO 6 CINEMA, DTS NEO 6 MUSIC, THEATER, HALL and MATRIX

- When the analog input is selected as signal input and analog stereo signals are input, you can select the desired of these above surround modes, too.
- However, when DTS signals are input in the IN-AUTO or IN-DTS mode, the corresponding DTS mode will be selected regardless of using the DDSP MODE ◀ or ▶ button.

■ Notes:

- When the selected decoding mode is not matched to the input signal format, the "DIGITAL" indicator flickers and no sound is heard. Therefore, be sure to select the required decoding mode and the available surround mode according to the input signal format.
- When the 7 CH DIRECT is selected as an input source, the decoding and surround modes cannot be selected.
- When the digital signals are not inputted, the desired surround mode cannot be selected.

ENGLISH

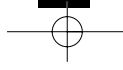

- To cancel the surround mode for stereo operation

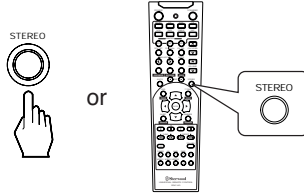

- Then the stereo mode is selected.
- To cancel the stereo mode, select the desired surround mode with using the DSP MODE ◀ or ▶ button.

Adjusting the Dolby Pro Logic II Music parameters

- When selecting the Dolby Pro Logic II Music mode, you can adjust the various surround parameters for optimum surround effect.

3 Press the PL II MUSIC PARAMETER button to select the desired parameter.

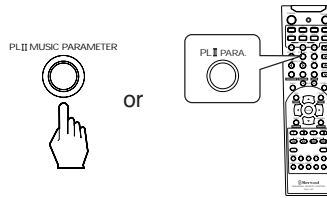

- Each time this button is pressed, the parameter changes and is displayed for several seconds as follows;

※ **Panorama mode ("PANO", default value : OFF)**

This mode extends the front stereo image to include the surround speakers for an exciting "wraparound" effect with side wall imaging. Select "OFF" or "ON".

※ **Center width control ("C-WID", default value : 0)**

This adjusts the center image so it may be heard only from the center speaker, only from the left/right speakers as a phantom image, or from all three front speakers to varying degrees. The control can be set in 8 steps from 0 to 7.

※ **Dimension control ("DIMEN", default value : 0)**

This gradually adjusts the soundfield either towards the front or towards the rear. The control can be set in 7 steps from -4 to +2.

4 At the desired parameter, adjust it as desired.

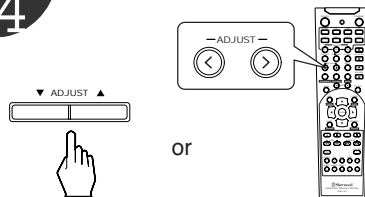

- If the parameter display disappears, start from the step 3 again.

5 Repeat the above steps 3 and 4 to adjust other parameters.

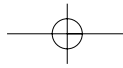

Adjusting each channel level

6 Select the desired channel.

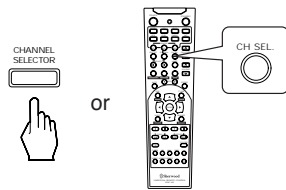

- Each time this button is pressed, the corresponding channel is selected and displayed for several seconds as follows:

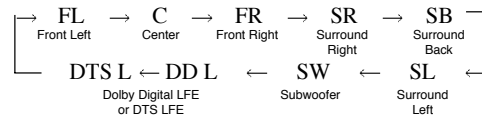

- You can adjust the LFE level for Dolby Digital or DTS program source that includes LFE signal.
- When it is in the stereo or Dolby Virtual mode or the speaker setting is "N", center, surround L/R, surround back or subwoofer channel will not be selected.
- When the SPEAKER button is set to off, only the front L/R channel can be selected.

7 Adjust the level of the selected channel as desired.

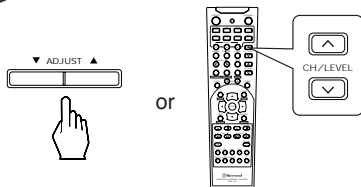

- The LFE level can be adjusted within the range of -10~0 dB and other channel levels within the range of -15~+15 dB.
- In general, we recommend the LFE level to be adjusted to 0 dB. (However, the recommended LFE level for some early DTS software is -10 dB.) If the recommended levels seem too high, lower the setting as necessary.
- If the channel display disappears, start from the step 6 again.

8 Repeat the above steps 6 and 7 to adjust each channel level.

Adjusting each channel level with test tone

- The volume level of each channel can be adjusted easily with the test tone function.
- Note : When the 7 CH DIRECT is selected as an input source or the SPEAKER button is set to off, the test tone function does not work.

9 Enter the test tone mode.

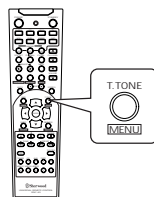

- The test tone will be heard from the speaker of each channel for 2 seconds as follows:

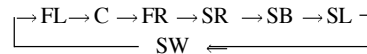

- When the speaker setting is "N", the test tone of the corresponding channel is not available.

ENGLISH



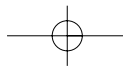

At each channel, adjust the level as desired until the sound level of each speaker is heard to be equally loud.

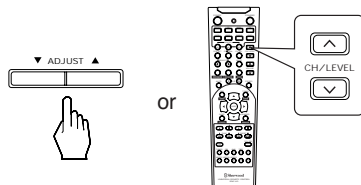

- You can select the desired channel and adjust its level with repeating the steps 6 and 7 in “Adjusting each channel level” procedure.

Cancel the test tone function.

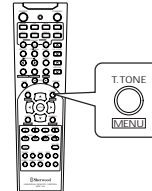

Downmixing into 2 front channels

- Allows the multi - channel DTS or Dolby Digital signal to be reproduced through only two speakers or through headphones.
- When the digital signals from the DTS or Dolby Digital program sources are input in available surround mode, press the STEREO button.

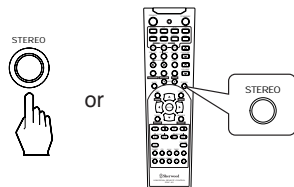

- “ST” indicator lights up and “2 CH DOWNMIX” is scrolled, meaning it enters the 2-CH downmix mode, and then the discrete multi-channels(except LFE) are mixed down into 2 front channels.

- To cancel the 2 - CH downmix mode, select the desired surround mode with the DSP MODE ◀ or ▶ button.
- When the playback of the source on the player is stopped, interrupted, etc., the 2 - CH downmix mode is not canceled even though “ ST ” and the DTS or Dolby Digital indicators go off.
- If the headphones are plugged in and the SPEAKER button is set to off while the digital signals from the DTS or Dolby Digital program sources are being input, it will enter the 2-CH downmix mode automatically(but only the DTS or Dolby Digital indicator lights up still) and if the headphones are unplugged and the SPEAKER button is set to on in the 2-CH downmix mode, it will return to the previous mode.



LISTENING TO RADIO

Auto tuning

1 Select the tuner.

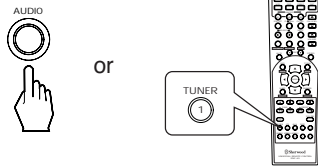

2 Select the desired band.

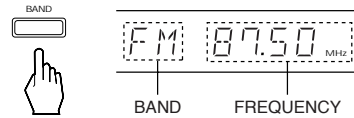

- Each time this button is pressed, the band is changed to FM or AM.
- When pressing the BAND button without selecting the TUNER, the tuner will be selected automatically.

3 Select the tuning mode.



- Each time this button is pressed, the mode changes as follows;

→ Tuning mode : “PRESET” goes off. ←
← Preset mode : “PRESET” lights up. →

4 Press the TUNING(/PRESET) UP(▲/+) or DOWN(▼/-) button for more than 0.5 second.

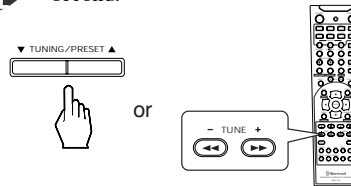

- The tuner will now search until a station of sufficient strength has been found. The display shows the tuned frequency and “TUNED”.
- If the station found is not the desired one, simply repeat this operation.
- Weak stations are skipped during auto tuning.
- When pressing the TUNE +/- buttons on the remote control, you need not select the tuning mode on step 3.

Manual tuning

- Manual tuning is useful when you already know the frequency of the desired station.
- Perform the steps 1 to 3 in “Auto tuning” procedure and press the TUNING(/PRESET) UP(▲/+) or DOWN(▼/-) button repeatedly until the right frequency has been reached.

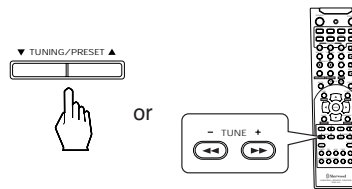

Presetting radio stations

- You can store up to 30 preferred stations in the memory.

1 Tune in the desired station with auto or manual tuning.

2 Press the MEMORY/ENTER button.



- “MEM” is flickering for 5 seconds.

3 Select the desired preset number (1~30) and press the MEMORY/ENTER button.

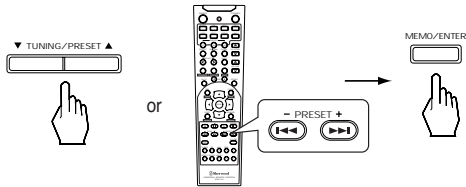

- The station has now been stored in the memory.
- A stored frequency is erased from the memory by storing another frequency in its place.
- If "MEM" goes off, start again from the above step 2.

4 Repeat the above steps 1 to 3 to memorize other stations.

MEMORY BACKUP FUNCTION

The following items, set before the receiver is turned off, are memorized.

- INPUT SELECTOR settings
- Surround mode settings
- Preset stations, etc.

Note : If the electricity fails or the AC input cord is disconnected for more than 2 weeks, they are all cleared. So you should memorize them again.

Tuning to preset stations

1 After selecting the tuner as an input source, select the preset mode.



- Then "PRESET" lights up.

2 Select the desired preset number.

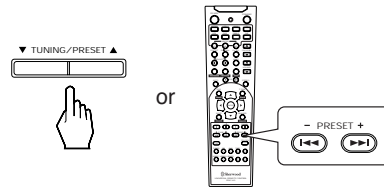

- When pressing the PRESET +/- buttons on the remote control, you need not select the preset mode on step 1.

Listening to FM stereo broadcasts

- While listening to FM broadcasts.



- Each time this button is pressed, the FM mode changes as follows;

- ↳ Stereo mode : "ST" lights up. ↪
- ↳ Mono mode : "ST" goes off. ↪

- When FM stereo broadcasts are poor because of weak broadcast signals, select the FM mono mode to reduce the noise, then FM broadcasts are reproduced in monaural sound.

Scanning preset stations in sequence

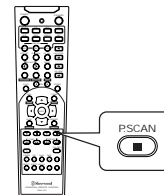

- The receiver will start scanning the stations in the preset sequence and each station is received for 5 seconds.
- At the desired station, press this button again to stop scanning.

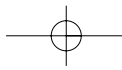

RECORDING

- The analog signals from the 7 CH DIRECT inputs as well as the digital signals from the coaxial or optical digital input can be heard but cannot be recorded.
- The volume and tone (bass, treble) settings have no effect on the recording signals.

ENGLISH

Recording with TAPE

- 1 Select the desired input as a recording source except for TAPE.

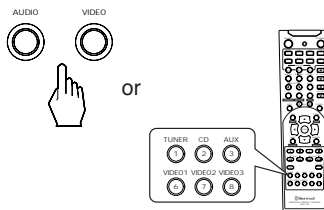

- 2 Start recording on the TAPE.

- 3 Start play on the desired input.

Dubbing from video components onto VIDEO 1

- 1 Select VIDEO 2 or VIDEO 3 as a recording source.

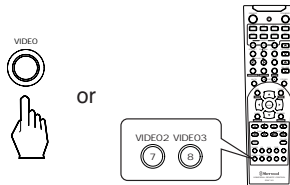

- 2 Start recording on the VIDEO 1.

- 3 Start play on the VIDEO 2 or the VIDEO 3.

- The audio and video signals from the VIDEO 2 or the VIDEO 3 will be dubbed onto the VIDEO 1 and you can enjoy them on the TV set and from the speakers.

Dubbing the audio and video signals separately onto VIDEO 1

Example) When dubbing the VIDEO 2 video signal and the CD audio signal separately onto VIDEO 1.

- 1 Select VIDEO 2 as a video recording source.

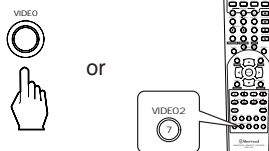

- 2 Select CD as an audio recording source.

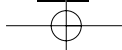
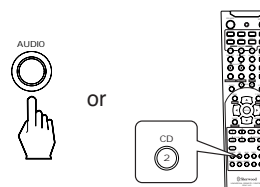

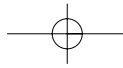



<p>3 Start recording on the VIDEO 1.</p>	<p>4 Start play on the VIDEO 2 and the CD respectively.</p> <ul style="list-style-type: none"> The audio signal from the CD and the video signal from the VIDEO 2 will be dubbed and you can enjoy them on the TV set and from the speakers. <p>Note : Be sure to observe the order of the above steps 1 and 2.</p>
---	---

DIGITAL AUDIO RECORDING WITH

- Only when the OPTICAL DIGITAL OUT of this receiver is connected to the OPTICAL DIGITAL IN of the MD recorder or CD recorder, you can enjoy high-quality sound of digital recording without converting the original signals. Refer to "CONNECTING AUDIO/VIDEO COMPONENTS" and "CONNECTING DIGITAL INs and OUT" on page 6 and 7 and the operating instructions of the MD recorder or CD recorder.

■Notes:

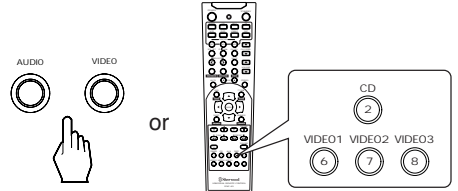
- Digital recording is available for the digital audio program sources such as CDs, MDs, some DVDs, etc.
- In most DVDs as well as some CDs, etc., digital recording may not be available depending on the signal format.
- There are some restrictions on recording digital signals. When making digital recordings, refer to the operating instructions of your digital recording equipment to know what restrictions are imposed.

<p>1 Select a desired input of CD, VIDEO 1~3 as a recording source.</p> 	<p>2 For digital recording, select the desired digital input as recording signal input.</p>  <ul style="list-style-type: none"> Each time this button is pressed, the corresponding input is selected as follows: A(nalog) → c(oaxial) 1 → c(oaxial) 2 o(optical) 2 ← o(optical) 1 ← <p>■Note : When the selected digital input is not connected, "DIGITAL" indicator flickers. There will be no recording as well as no sound.</p>
<p>3 Start recording on the component connected to OPTICAL DIGITAL OUT.</p>	<p>4 Start play on the desired input.</p>

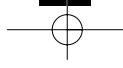

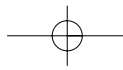

OTHER FUNCTIONS

Compressing the dynamic range (Dolby Digital sources only)

- This function compresses the dynamic range of previously specified parts of the Dolby Digital sound track (with extremely high volume) to minimize the difference in volume between the specified and non-specified parts. This makes it easy to hear all of the sound track when watching movies at night at low levels.
- When the digital signals from Dolby Digital program source are input in available surround mode.



- Each time this button is pressed, the mode changes and the display scrolls.

↓
DYNR 0.0 : Off
↓
DYNR 0.5 : Low compression
↓
DYNR 1.0 : High compression

- In some Dolby Digital softwares, this function may not be available.

Operating the sleep timer

- The sleep timer allows the system to continue to operate for a specified period of time before automatically shutting off.
- To set the receiver to automatically turn off after the specified period of time.

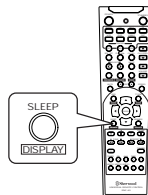

- Each time this button is pressed, the sleep time changes and "GOOD NIGHT" message scrolls.
→ 10 → 20 → 30 → 60 → 90 → OFF
Unit : minutes
- While operating the sleep timer, "SLEEP" lights up.
- When the sleep time is selected, all display panels of Sherwood components connected by the DIGI LINK III are dimly lit.

Adjusting the brightness of the fluorescent displays

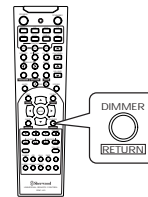

- Each time this button is pressed, the brightness of all fluorescent displays of Sherwood components connected by the DIGI LINK III changes together as follows;

→ ON → dimmer → OFF →

- In the display OFF mode, pressing any button will restore the display ON mode.

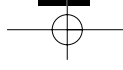

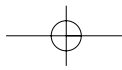

Using the OSD

This unit incorporates an OSD(On-screen display) function to provide information about basic operation of this unit and to simplify the setup procedures.

The OSD function uses a monitor TV connected to this unit as a display and has two kinds of display modes such as current status display and menu screen.

■Note:

- Any on-screen display shown on the monitor TV will not be recorded onto VIDEO 1.

CURRENT STATUS DISPLAY

When the AUTO OSD mode is set to ON on the menu screen, this mode shows the status corresponding to each operation.

- The on-screen display will automatically disappear in several seconds.
- For examples, there are 2 status displays as follows.

■When selecting the desired input source

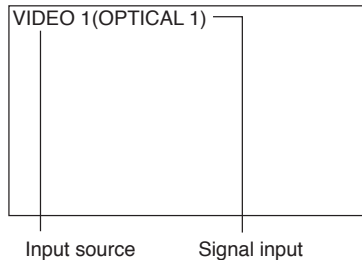

■When selecting the TEST TONE mode

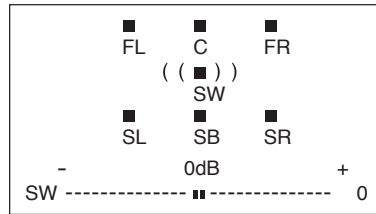

- When the speaker setting is “N”, the test tone of the corresponding channel is not shown.
- When adjusting each channel level or overall volume, the volume level display will be shown.
- The test tone display will be shown until the test tone mode is canceled.

MENU SCREEN

- This function simplifies the setup procedures.
- The menu screen operation is performed easily with the CURSOR control(▲, ▼, ◀, ▶), OSD and ENTER buttons.

1

Turn the menu screen on.

- The main menu will be shown.
- To turn the menu screen off, press this button.

MAIN MENU

▶ SPEAKER SETUP
FUNCTION SELECT
SURROUND MODE
CH LEVEL TRIM
AUTO OSD : ON

up/down : MOVE
OSD:END ENTER : SEL.

Main menu display

- In the bottom of the display, “up” stands for the CURSOR UP(▲) button, “down” for the CURSOR DOWN(▼), “←” for CURSOR LEFT(◀), “→” for CURSOR RIGHT(▶), “OSD” for OSD button, “ENTER” for ENTER button.

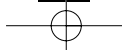

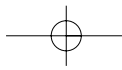

2

Select the desired menu using the CURSOR UP(▲) or DOWN(▼) button.

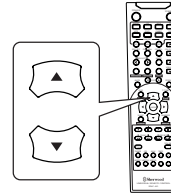

3

Confirm your selection.

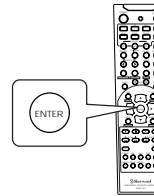

■ When selecting the SPEAKER SETUP

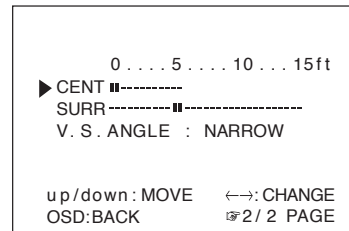
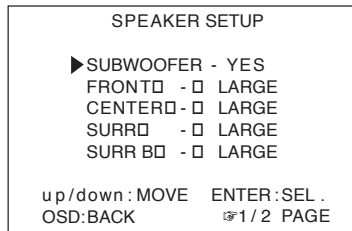

■ When selecting the FUNCTION SELECT

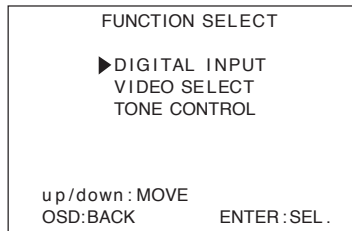

■ When selecting the SURROUND MODE

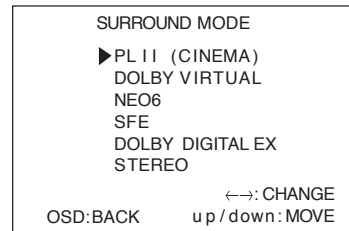

- Only when one of TUNER, CD, TAPE and AUX is selected, you can select a video input source on the VIDEO SELECT menu and enjoy the audio and video signals separately.
- When dubbing them onto VIDEO 1, select either VIDEO 2 or VIDEO 3 on the VIDEO SELECT menu.

■ When selecting the CH LEVEL TRIM

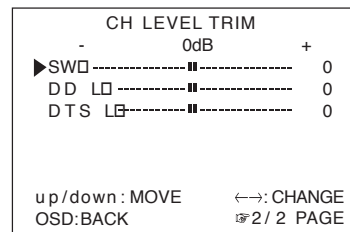
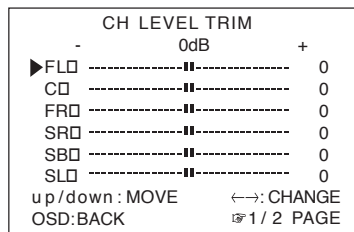

- According to your selections for the input source, input signal, decoding mode, surround mode, speaker settings, etc., the conditions of each menu may differ.
- When adjusting the distance difference or channel level, etc., use the CURSOR LEFT(◀) and RIGHT(▶) buttons.

■ When selecting the AUTO OSD

- Each time the ENTER button is pressed, the AUTO OSD mode is set to ON to turn on the current display or OFF to turn it off.
- When the AUTO OSD mode is set to ON, the current status display overlays the program image on the monitor TV and may interference with your movie enjoyment. In such a case, set it to OFF.

ENGLISH

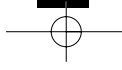

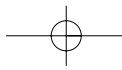

4

Select the desired menu or(and) change the condition with the corresponding buttons.

5

Repeat the above steps 2~4 to change the conditions on other menus.

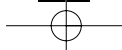

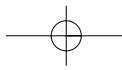

Troubleshooting Guide

If a fault occurs, run through the table below before taking your receiver for repair. If the fault persists, attempt to solve it by switching the receiver off and on again. If this fails to resolve the situation, consult your dealer. Under no circumstances should you attempt to repair the receiver yourself. This could void the warranty.

ENGLISH

PROBLEM	POSSIBLE CAUSE	REMEDY
No power	<ul style="list-style-type: none"> The AC input cord is disconnected. Poor connection at AC wall outlet or the outlet is inactive. 	<ul style="list-style-type: none"> Connect the cord securely. Check the outlet using a lamp or another appliance.
No sound	<ul style="list-style-type: none"> The speaker cords are disconnected. The master volume is adjusted too low. The MUTE button on the remote control is pressed to ON. Speakers are not switched on. Incorrect selection of the input source. Incorrect connections between the components. 	<ul style="list-style-type: none"> Check the speaker connections. Adjust the master volume. Press the MUTE button to cancel the muting effect. Press the SPEAKER button to ON. Select the desired input source correctly. Make connections correctly.
No sound from the surround speakers	<ul style="list-style-type: none"> Surround mode is switched off (stereo mode). Master volume and surround level are too low. A monaural source is used. Surround speaker setting is "N". 	<ul style="list-style-type: none"> Select a surround mode. Adjust master volume and surround level. Select a stereo or surround source. Select the desired surround speaker setting.
No sound from the center speaker	<ul style="list-style-type: none"> Dolby Virtual, stereo mode, etc. is selected. Center speaker setting is "N". Master volume and center level are too low. 	<ul style="list-style-type: none"> Select the desired surround. Select the desired center speaker setting. Adjust master volume and center level.
No sound from the surround back speaker	<ul style="list-style-type: none"> The input signal format or the current surround mode cannot support the 6.1 surround playback. Master volume and surround back level are too low. Surround back speaker setting is "N". 	<ul style="list-style-type: none"> Under the proper situations, perform the 6.1 surround playback. Adjust master volume and surround back level. Select the desired surround back speaker setting.
Stations cannot be received	<ul style="list-style-type: none"> No antenna is connected. The desired station frequency is not tuned in. The antenna is in wrong position. 	<ul style="list-style-type: none"> Connect an antenna. Tune in the desired station frequency. Move the antenna and retry tuning.
Preset stations cannot be received	<ul style="list-style-type: none"> An incorrect station frequency has been memorized. The memorized stations are cleared. 	<ul style="list-style-type: none"> Memorize the correct station frequency. Memorize the stations again.
Poor FM reception	<ul style="list-style-type: none"> No antenna is connected. The antenna is not positioned for the best reception. 	<ul style="list-style-type: none"> Connect an antenna. Change the position of the antenna.
Continuous hissing noise during FM reception, especially when a stereo broadcast is received.	<ul style="list-style-type: none"> Weak signals. 	<ul style="list-style-type: none"> Change the position of the antenna. Install an outdoor antenna.
Continuous or intermittent hissing noise during AM reception, especially at night.	<ul style="list-style-type: none"> Noise is caused by motors, fluorescent lamps or lightning, etc. 	<ul style="list-style-type: none"> Keep the receiver away from noise sources. Install an outdoor AM antenna.
Remote control unit does not operate.	<ul style="list-style-type: none"> Batteries are not loaded or exhausted. The remote sensor is obstructed. 	<ul style="list-style-type: none"> Replace the batteries. Remove the obstacle.
Other Sherwood components do not react to remote control commands.	<ul style="list-style-type: none"> DIGI LINK connections are not made properly. 	<ul style="list-style-type: none"> Make proper DIGI LINK connections.
OSD function is not available	<ul style="list-style-type: none"> Video connections between this unit and the TV monitor are not made correctly. 	<ul style="list-style-type: none"> Make proper video connections.

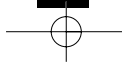

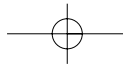

Specifications

■AMPLIFIER SECTION

• Power output, stereo mode, 6 Ω, THD 0.2 %, 40 Hz~20 kHz	2 × 100 W
• Total harmonic distortion, 6 Ω, 95 W, 1 kHz	0.09%
• Intermodulation distortion	
60 Hz : 7 kHz= 4 : 1 SMPTE, 6 Ω, 95 W	0.1%
• Input sensitivity, 47 kΩ	
Line (CD, TAPE, VIDEO)	200 mV
• Signal to noise ratio, IHF "A" weighted	
Line (CD, TAPE, VIDEO)	90 dB
• Frequency response	
Line (CD, TAPE, VIDEO), 20 Hz~50 kHz	+0 dB, -3 dB
• Output level	
TAPE REC, 2.2 kΩ	200 mV
• Bass/Treble control, 100 Hz/10 kHz	± 10 dB
• Surround mode, only channel driven	
Front power output, 6 Ω, 1 kHz, THD 0.7 %	110 W+110 W
Center power output, 6 Ω, 1 kHz, THD 0.7 %	110 W
Surround power output, 6 Ω, 1 kHz, THD 0.7 %	110 W+110 W
Surround back power output, 6 Ω, 1 kHz, THD 0.7 %	110 W

■DIGITAL AUDIO SECTION

• Sampling frequency	32, 44.1, 48, 96 kHz
• Digital input level	
Coaxial, 75 Ω	0.5 V _{p-p}
Optical, 660 nm	-15~-21 dBm

■VIDEO SECTION

• Video format	NTSL
• Input sensitivity(=Output level), 75 Ω	
Video (Composite(normal))	1 V _{p-p}
S-Video (luminance signal)	1 V _{p-p}
(chrominance signal)	0.286 V _{p-p}

■FM TUNER SECTION

• Tuning frequency range	87.5~108 MHz
• Usable sensitivity, THD 3%, S/N 30 dB	12.8 dBf
• 50 dB quieting sensitivity, mono/stereo	20.2/45.3 dBf
• Signal to noise ratio, 65 dBf, mono/stereo	70/65 dB
• Total harmonic distortion, 65 dBf, 1 kHz, mono/stereo	0.5/0.8 %
• Frequency response, 30 Hz~15 kHz	±3 dB
• Stereo separation, 1 kHz	32 dB
• Capture ratio	4 dB
• IF rejection ratio	60 dB

■AM TUNER SECTION

• Tuning frequency range	520~1710 kHz
• Usable sensitivity	500 μV/m
• Signal to noise ratio	40 dB
• Selectivity	25 dB

■GENERAL

• Power supply	AC 120 V, 60 Hz
• Power consumption	2.5 A
• Switched AC outlet	TOTAL 1 A, 100 W max.
• Dimensions (W × H × D)	440 × 141 × 330 mm(17-3/8 × 5-1/2 × 13 inches)
• Weight (Net)	9.6 kg(21.2 lbs)

Note: Design and specifications are subject to change without notice for improvements.

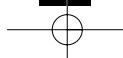

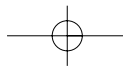

Setup Code Table

T V

AOC	005 003	Goldstar	005 025 003 011
Admiral	041 031	Gradiente	009 011
Aiko	014	Grunpy	027 026
Akai	005	Hallmark	025
Alaron	026	Harley Davidson	026
Ambassador	024	Harman/Kardon	010
America Action	027	Havard	027
Ampro	043	Hitachi	016 011 018
Anam	027 047 048 049	Infinity	010
Audiovox	030 027 014 034	Inteq	002
Baysonic	027	JBL	010
Belcor	003	JCB	050
Bell & Howell	019 001	JVC	009 046
Bradford	027	KEC	027
Brockwood	003	KTV	027 005 006
Broksonic	028 031	Kenwood	005 003
CXC	027	LG	011 003
Candle	005 011	LXI	007 010 019 020 025
Carnivale	005	Logik	001
Carver	010	Luxman	011
Celebrity	050	MGA	017 005 025 003
Cineral	030 014	MTC	012 005 003 011
Citizen	012 005 011 006 014	Magnavox	010 005 026
Concerto	011	Magestic	001
Contec	027	Marantz	010 005
Craig	027	Matsushita	042
Crosley	010	Magatron	025 016
Crown	027 006	Memorex	019 042 031 017 025 011
Curtis Mathes	007 010 019 008 030 041		001
	012 005 016 011 001 006	Midland	007 002 008 006 015
	022 032 038 040	Minutz	004
Daewoo	030 003 006 014 034 035	Mitsubishi	041 017 025 003
Daytron	003	Motorola	041
Denon	016	Multitech	027
Dumont	002 003	NAD	020 025 022
Dwin	044 036	NEC	005 003 011
Electroband	050	NTC	014
Emerson	019 028 031 027 029 025	Nikko	005 025 014
	003 026 006 024 034 035	Onwa	027
Envision	005	Optimus	019 042 022
Fisher	019	Optonica	041 021
Fujitsu	026	Orion	028 031 026
Funai	027 026 023	Panasonic	008 042
Futuretech	027	Penney	007 020 008 012 005 025
GE	007 008 030 041 029 025		004 003 011 006 015 040
	004 015 038 040	Pilco	010 031 005 016 003
		Philips	010

ENGLISH

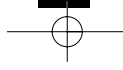

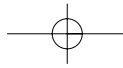

ENGLISH

Pilot	005 003 006
Pioneer	022
Portland	003 006 014
Prism	008
Proscan	007
Proton	025 032
Pulsar	002 003
Quasar	008 042 021
RCA	007 008 041 003 013 015 037 038 039 040
Radio Shack	007 019 021 027 005 025 003 011 006
Realistic	019 021 027 005 025 003 011 006
Runco	002 005 033
SSS	027 003
Sampo	005 006
Samsung	012 005 025 003 011 045
Samsux	006
Sansei	030
Sansui	031
Sanyo	019
Scimitsu	003
Scotch	025
Scott	028 027 025 003 026
Sears	007 010 019 020 025 026 011 006
Semivox	027
Semp	020
Sharp	041 021 006
Sherwood	000
Shogun	003
Signature	001
Sony	050
Soundesign	027 025 026
Squareview	023
Starlite	027
Supreme	050
Sylvania	010 005
Symphonic	023
T M K	025 011 024
Tandy	041
Technics	008 042
Technoi Ace	026
Techwood	008 011
Teknika	010 027 017 012 003 026 011 001 006 014
Telefunken	011
Toshiba	019 020 012
Totevision	006
Vector Research	005
Victor	009

Vidtech	025 003
Wards	010 021 005 025 004 003 026 011 001
White Westinghouse	031 034 035
Yamaha	005 003
Zenith	002 031 001 014

VCR

Admiral	027 021
Adventura	000
Aiko	025
Aiwa	005 000
Akai	026
America Action	025
America High	004
Asha	023
Audiovox	005
Beaumarck	023
Bell & Howell	017
Brocksonic	021
Broksonic	020 018 021 001
CCE	015 025
Calix	005
Canon	004
Carver	081
Cineral	025
Citizen	005 025
Colt	015
Craig	005 012 023 015 024
Curtis Mathes	013 004 026 028
Cybernex	023
Daewoo	010 025
Denon	008
Dynatech	000
Electrohome	005
Electroponic	005
Emerex	002
Emerson	005 020 000 018 009 021 001 025
Fisher	012 017
Fuji	004 003
Funai	000
GE	013 004 027 023
Garrard	000
Go Video	052
GoldStar	005 006
Gradiente	000
HI-Q	012
Harley Davidson	000
Harman/Kardon	016 006



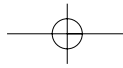

Headquarter 011
 Hitachi 000 008 026
 Hughes Net.Sys 008
 JVC 014 026
 Jensen 026
 KEC 005 025
 KLH 015
 Kenwood 014 026 006
 Kodak 004 005
 LXI 005
 Lloyd's 000
 Logik 015
 MEI 004
 M G A 023 009
 MGN Technology 023
 M T C 023 000
 Magnasonic 025
 Magnavox 004 007 016 000 019
 Magnin 023
 Marantz 004 016
 Marta 005
 Matsushita 004 028 029
 Memorex 004 005 027 007 012 023
 000 017 021 011 031 032
 Minolta 008
 Mitsubishi 027 014 009
 Motorola 004 027
 Multitech 000 015
 NEC 017 014 026 006
 Nikko 005
 Noblex 023
 Olympus 004
 Opimus 005 027 017 028 029 030
 031 032
 Orion 020 021 001
 Panasonic 004 028 022 029 031
 Penny 004 005 023 008 006
 Pentax 008
 Philco 004 021
 Philips 004 016
 Pilot 005
 Pioneer 014
 Profitronic 023
 Proscan 013
 Protec 015
 Pulsar 007
 Quarter 011
 Quartz 011
 Quasar 004 028 029 031
 RCA 013 004 027 023 008 019
 Radio Shack 000
 Radix 005

Realistic 004 005 027 012 000 017
 011
 Runco 007
 STS 008
 Samsung 023 010 033
 Sanky 027 007
 Sansui 000 014 021 026 024
 Sanyo 012 023 017 011
 Scott 020 010 018 009
 Sears 004 005 012 000 008 017
 011
 Semp 010
 Sharp 027
 Shintom 015
 Shogun 023
 Singer 015
 Sony 004 002 000 003
 Sylvania 004 016 000 009
 Symphonic 000
 T M K 023
 Tatung 026
 Teac 000 026
 Technics 004 028
 Teknika 004 005 000
 Thomas 000
 Toshiba 010 009
 Totevision 005 023
 Unitech 023
 Vector 010
 Vector Research 006
 Video Concepts 010
 Videosonic 023
 Wards 013 004 027 012 016 023
 000 008 015 019
 White WestingHouse 021 025
 XR-100 004 000 015
 Yamaha 006
 Zenith 007 000 021 003
 Ameira High 004 (TV use 008)
 Brocksonic 001
 Colt 015
 Cutis Mathes 004 (TV use 008)
 Daewoo 025
 Emerson 001
 Funai 000
 GE 004 (TV use 008) 013 (TV
 use 012)
 Hitachi 027 (TV use 041) 023
 004 (TV use 008) 000
 H Q 000
 Lloyds 000
 M G A 023

ENGLISH

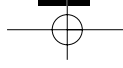

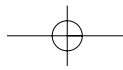

ENGLISH

Magnin	023
Memorex	005 028 (TV use 025)
Mitsubishi	027 (TV use 041)
Orion	001
Panasonic	004 (TV use 008) 028 (TV use 042)
Penney	004 (TV use 008) 023 028 (TV use 042)
Quasar	004 (TV use 008) 028 (TV use 042)
RCA	013 (TV use 012) 004 (TV use 008) 027 (TV use 041)
Sansui	000
Sanyo	023
Sear	000 005
Sharp	027 (TV use 041)

DVD

Harman/Kardon	009
JVC	008
Kenwood	005
Megavox	011
Mitsubishi	016
Onkyo	011
Panasonic	013
Philips	011 006
Pioneer	003 014 026
Proscan	002
RCA	002
Samsung	017
Sherwood	001 012 000 018 019 020 021 022 023 025
Sony	004
Technics	013
Theta Digital	014
Toshiba	011
Yamaha	013 007
Zenith	011 010

CBL

ABC	002 003 009 030
Allegro	007 006 008
Archer	018 021
Bell&Howell	018 026
Century	009
Citizen	018
Comtronics	018 021
Contec	014
Easten	011
Emerson	001
Everquest	026
Focus	010 014
Garrard	022
Gemini	018
General Instrument	010
GoldStar	033 276 006 034
Goodmind	017 040
Hamlin	026
Hitachi	012 020 004 013
Hytex	006
Jasco	007
Jerrold	010 018 021
Memorex	002 007 033 032 009 010
Movie Time	006 034
NSC	000
Oak	015
Optimus	011
Panasonic	031
Paragon	000 016 031
Philips	000
Pioneer	018
Popular Mechanics	017 025
Pulsar	022
Quasar	000
RCA	031
Radio Shack	010 021 026 028
Recoton	022
Regal	012 020
Regency	001
Rembrandt	006
Runco	000
SL Marx	014
Smasung	017 014
Scientific Atlanta	003 023 030 027
Signal	010 014
Signature	006
Sprucer	031
Starcom	002 010



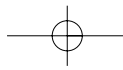

Stargate	010 014 026
Starquest	010
TV86	015
Televiue	014
Tocom	007 008
Toshiba	000
Tusa	010
Unika	018
United Artists	007
Universal	153 019
Viewstar	015
Zenith	000 024

SAT

AlphaStar	008
Chaparral	001
Echostar	009
Expreevu	009
General Instrument	016 015 018
HTS	009
Hitachi	011
Hughes Net.Sys	007
JVC	009
Jerrold	016 015
Megavox	006 005
Memorex	006
Next Level	006
Panasonic	017
Philips	006 005
Primestar	016 015
RCA	003 000 002 012
Radio Shack	018
Realistic	014
Sony	004
Star Choice	018
Toshiba	010
Uniden	006 005 014

AUX-

Sherwood	000 (for tape deck)
	035 (for MD recorder)

AUX-LD

Denon	007
Mitsubishi	007
NAD	007
Pioneer	007
Sony	017 018

AUX-

Aiwa	004 034
Carver	004
Harman/Kardon	016 004
JVC	022 024
Kenwood	008
Megavox	004
Marantz	004
Onkyo	012 025
Opimus	002 020
Panasonic	038
Pioneer	002 020 011
Sansui	004
Sony	021 014 026
Technics	038
Victor	024
Wards	002
Yamaha	010 009

AUX-AMP

Awia	029
Carver	023
Curtis Mathes	027
Denon	037
Harman/Kardon	040
Linn	023
Megavox	023
Marantz	023
Panasonic	039
Philips	023 040
Pioneer	003 027
Sony	019 033
Technics	039
Wards	003

ENGLISH

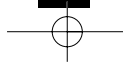

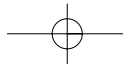

AUX-HOME AUTOMATION

GE	043
Lutron	044
One For All	042
Radio Shack	043
Security System	042
Universal X10	042
X10	042

AUX-DBS

Awia	045 059 029
Fisher	005
Harman/Kardon	046
JBL	046
JVC	047
Jerrold	031
RCA	006
Scientific Atlanta	032
Sony	045

AUX-ACCESSORY

Archer	013
GC Electronics	013
Jebsee	013
Rabbit	036

C D

Awia	010 030
Burmester	019
California Audio Lab	002
Carver	010 012 020
DKK	001
Denon	028 034
Emerson	035
Fisher	012 033
Garrard	019 018
Genexxa	004 035
Harman/Kardon	010 011
Hitachi	004
JVC	007

Kenwood	003 029 016 024 025
Krell	010
LXI	035
Linn	010
MCS	002
MTC	019
Megavox	010 035
Marantz	002 010 013
Mission	010
NSM	010
Nikko	033
Onkyo	008 026
Opimus	001 004 012 035 029
	019 009 021 020
Panasonic	002 031
Parasound	019
Philips	010 023
Pioneer	004 035 021 017
Proton	010
QED	010
Quasar	002
RCA	012 035 006 036
Realistic	012 019 013
Rotel	010 019
SAE	010
Sansui	010 035
Sanyo	012
Scott	035
Sears	035
Sharp	029 013 037
Sherwood	013 027 038 039 040 041
	000
Sony	001 014 022
Soundesign	009
Tascam	019
Teac	019 018 033 013
Technics	002 031
Victor	007
Wards	010 006
Yamaha	005 015

